

# The Heavy Duty Nonmetallic **CABLE RACK**



For Power and Communications Manholes And Vaults



## **PRODUCT FEATURES:**

- High Load Capacity
- Will Not Rust or Corrode
- No Grounding or Bonding
- Insulators Not Required
- Excellent Dielectric Properties
- Molded from UL Listed Glass Reinforced Polymer



HDL Arm Lock shown with RA04 Arm and CR36-B Stanchion



3HDS - 3' throat saddle shown with a cable secured by cable ties.



RA08 - 8' arm shown with three cables secured by cable ties.

US PATENT No. 7,140,500  
CANADIAN PATENT Nos. 2,486,904 - 2,640,899



# RACK ARM COMPONENT PARTS

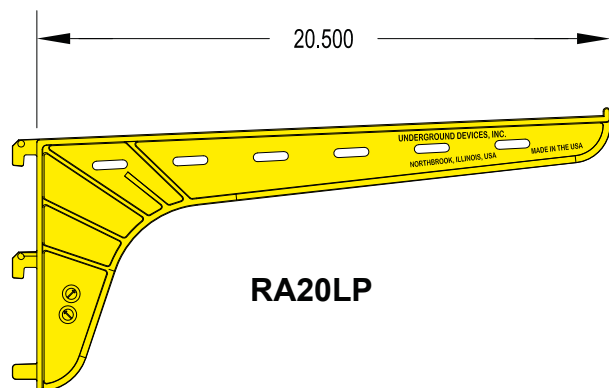
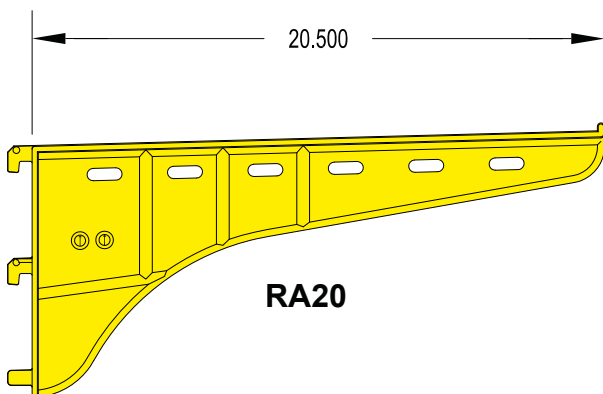
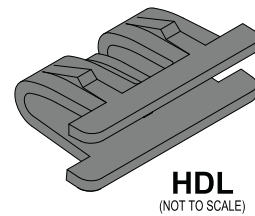
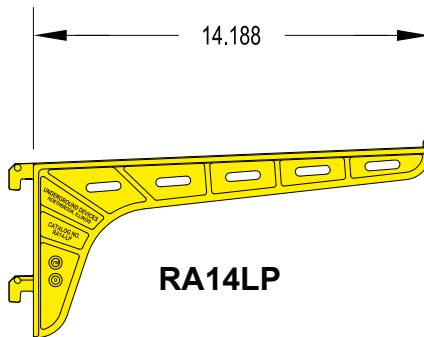
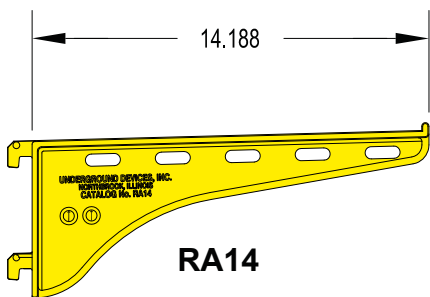
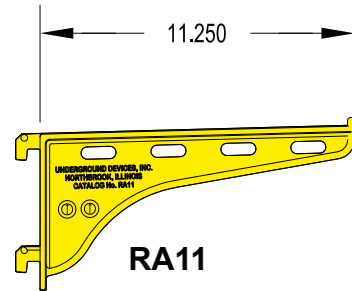
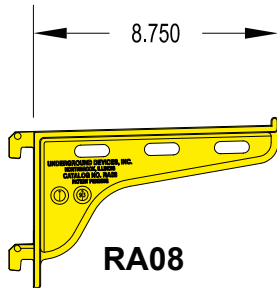
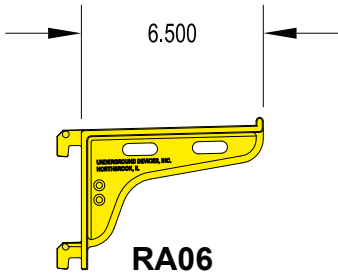
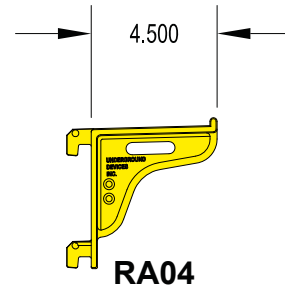
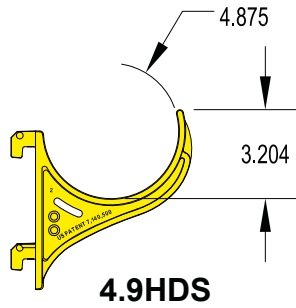
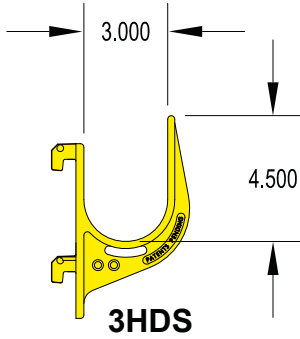

# RACK ARM ORDERING & TECHNICAL INFORMATION

<b>ARM ORDERING INFORMATION</b>						
CATALOG NUMBER	DESCRIPTION	STANDARD CARTON				
		QUANTITY	WEIGHT (LBS.)	LENGTH (INCHES)	WIDTH (INCHES)	HEIGHT (INCHES)
3HDS	3" SADDLE	10	8	15.250	10.750	6.375
4.9HDS	4.9" SADDLE	10	10	15.125	13.125	5.750
RA04	4" ARM	10	8	15.375	6.000	6.875
RA06	6" ARM	10	10	16.125	9.125	5.375
RA08	8" ARM	10	12	11.375	8.125	13.375
RA11	11" ARM	10	15	12.625	8.125	15.125
RA14	14" ARM	10	18	16.125	8.250	15.500
RA14LP	14" LOW PROFILE ARM	10	18	15.625	7.750	20.125
RA20	20" ARM	10	33	22.000	11.875	15.000
RA20LP	20" LOW PROFILE ARM	10	33	22.125	11.000	16.000
HDL	ARM LOCK	50	1	5.000	4.000	4.000

<b>RATED LOAD CARRYING CAPACITY</b>				
CATALOG NUMBER	DESCRIPTION	STANDARD CARTON		
		ARM LENGTH	RATED LOAD (LBS)*	DEFLECTION (INCHES)*
3HDS	3" SADDLE	3" SADDLE	450	---
4.9HDS	4.9" SADDLE	4.9" SADDLE	300	---
RA04	4" ARM	4"	450	.082
RA06	6" ARM	6"	450	.156
RA08	8" ARM	8"	450	.218
RA11	11" ARM	11"	400	.250
RA14	14" ARM	14"	350	.312
RA14LP	14" LOW PROFILE ARM	14"	350	.325
RA20	20" ARM	20"	250	.234
RA20LP	20" LOW PROFILE ARM	20"	250	.294

\* Concentrated load and deflection 1" from end of arm.



# STANCHION COMPONENT PARTS

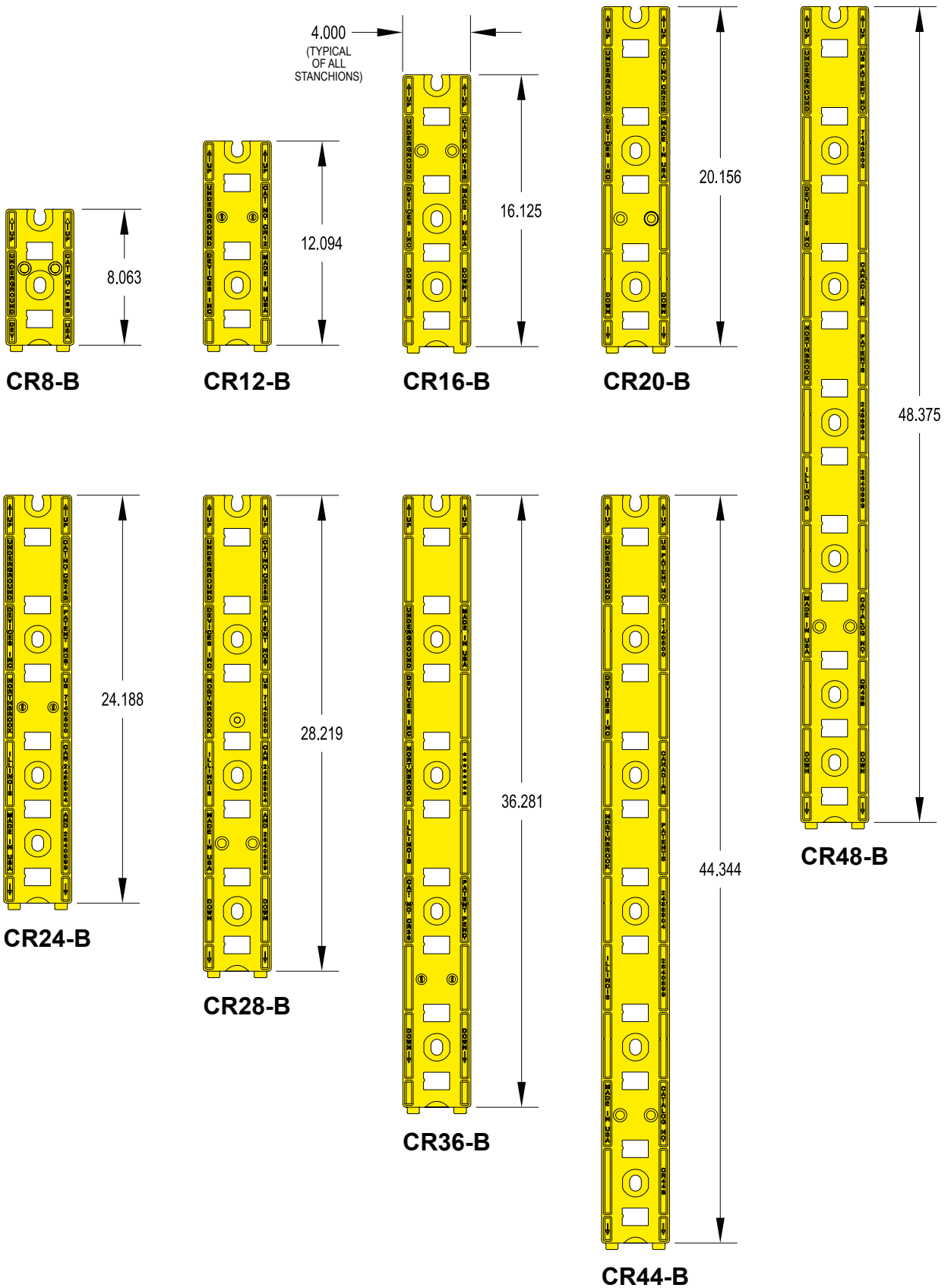

# STANCHION & MOUNTING HARDWARE ORDERING INFORMATION

<b>STANCHION ORDERING INFORMATION</b>							
CATALOG NUMBER	DESCRIPTION	STANDARD CARTON					HARDWARE SETS REQ'D.
		QUANTITY	WEIGHT (LBS.)	LENGTH (INCHES)	WIDTH (INCHES)	HEIGHT (INCHES)	
CR8-B	8" STANCHION	10	9	8.500	8.000	5.000	2
CR12-B	12" STANCHION	10	13	12.625	8.000	5.000	2
CR16-B	16" STANCHION	10	17	16.625	8.000	5.000	3
CR20-B	20" STANCHION	10	21	20.625	8.000	5.000	3
CR24-B	24" STANCHION	10	26	25.250	8.500	5.000	4
CR28-B	28" STANCHION	10	30	29.250	8.500	5.000	4
CR36-B	36" STANCHION	10	40	37.250	8.500	5.000	5
CR44-B	44" STANCHION	6	28	46.125	9.000	4.875	6
CR48-B	48" STANCHION	6	31	50.125	9.000	4.875	7

<b>DROP-IN ANCHOR ORDERING INFORMATION</b>							
CATALOG NUMBER	DESCRIPTION	STANDARD CARTON					
		QUANTITY	WEIGHT (LBS.)	LENGTH (INCHES)	WIDTH (INCHES)	HEIGHT (INCHES)	
FSRM-12	1/2" - 13 DROP-IN ANCHOR, 18-8 SS	40	5	5.750	4.500	2.500	
FFW-316-18-040	316 SS FLAT WASHER 0.56 ID X 1.25 OD X 0.078 THICK	80	2	4.000	3.500	2.500	
FHC-316-16-044	316 SS HEX HEAD CAP SCREW 1/2"-13 X 1 3/8"	40	4	5.750	4.500	2.500	
FRT-112	SETTING TOOL	1	1	5.500	1.000	1.000	

<b>CAST-IN INSERT ORDERING INFORMATION</b>							
CATALOG NUMBER	DESCRIPTION	STANDARD CARTON					
		QUANTITY	WEIGHT (LBS.)	LENGTH (INCHES)	WIDTH (INCHES)	HEIGHT (INCHES)	
FNMA-16	1/2" - 13 CAST-IN-PLACE INSERT	40	2	11.000	4.500	4.500	
FFW-316-18-040	316 SS FLAT WASHER 0.56 ID X 1.25 OD X 0.078 THICK	80	2	4.000	3.500	2.500	
FHC-316-16-088	316 SS HEX HEAD CAP SCREW 1/2"-13 X 2 3/4" WITH 2" MIN. FULL THREAD	40	7	5.750	4.500	4.500	



# CAST-IN-PLACE INSERT INSTALLATION INFORMATION

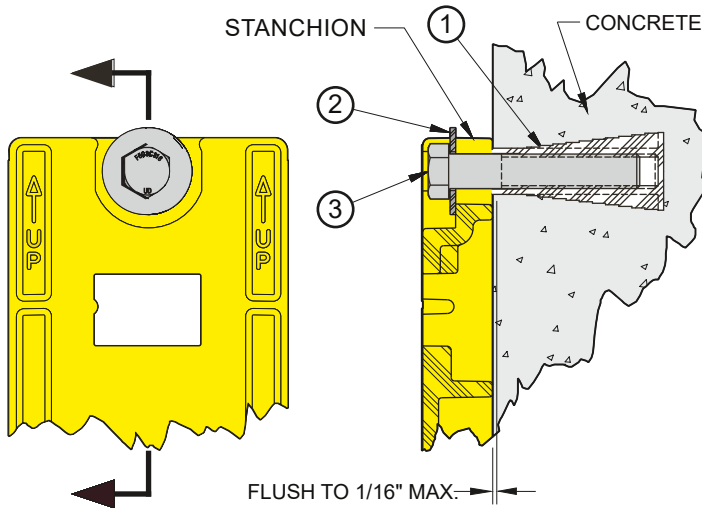

HARDWARE RECOMMENDED FOR SECURING THE HEAVY DUTY RACK STANCHION TO A PRECAST CONCRETE WALL		
ITEM NO.	CATALOG NUMBER	DESCRIPTION
①	FNMA-16	1/2" - 13 CAST-IN-PLACE NONMETALLIC INSERT
②	FFW-316-18-040	FLAT WASHER 0.56 ID X 1.25 OD X 0.078 THICK MATERIAL: 316 SS
③	FHC-316-16-088	HEX HEAD CAP SCREW 1/2"-13 X 2 3/4" WITH 2" MIN. FULL THREAD MATERIAL: 316 SS

#### INSERT LOAD CAPACITY:

1. Ultimate strength = 7,050 lbs. Working load = 1,763 lbs.
2. Ultimate load capacity is based on 4,100 psi 3/4" crushed limestone aggregate concrete. Based on independent testing laboratory tests. Copies of reports are available upon request.
3. For load capacities in structural lightweight aggregate concrete contact Underground Devices, Inc.
4. Safe working loads for single installations under static loading should not exceed 25% of the ultimate load capacity.

#### GENERAL INSERT NOTES:

1. Inserts are designed for preplanned fastening in concrete. The installation of the inserts can be done at a precast concrete manufacturing facility, or it can be accomplished onsite if the manhole is to be cast-in-place.
2. Prior to pouring concrete for the manhole, the inserts MUST be secured to the concrete forms at the locations for each mounting hole on the cable rack stanchion.

#### HEX HEAD CAP SCREW NOTES:

1. UDI Type 316 stainless steel cap screws conform to ASTM 316F593G and ASME B18.2.1.
2. "316F593G" and the manufacturer's identification number is stamped on the head of each Type 313 stainless steel screw.
3. The manufacturing lot number is marked on each carton of fasteners and has full traceability.
4. Upon request UDI will supply written certification that a given lot of fasteners conforms to the applicable specification.

### GENERAL INSTALLATION GUIDELINES For the highest cable rack load capacity:

1. Be sure surface of the concrete wall is smooth, flat and plumb and that the inserts are flush with the concrete wall.
2. Install one insert for every elongated stanchion hole.
3. Install the flat washer and tighten the cap screw just enough to attain a snug fit. Avoid high screw torque which induces compressive stress.
4. After assembling the arms to the stanchion, tap the arm down with a light mallet blow. The light mallet blow will fully seat and lock arm in place.
5. Install optional HDL lock by placing the lock on the arm with the locking barbs up. Push the lock into the rectangular hole in the stanchion. When the stop flanges on the lock hit the stanchion, the lock will click into place.

# DROP-IN ANCHOR INSTALLATION INFORMATION

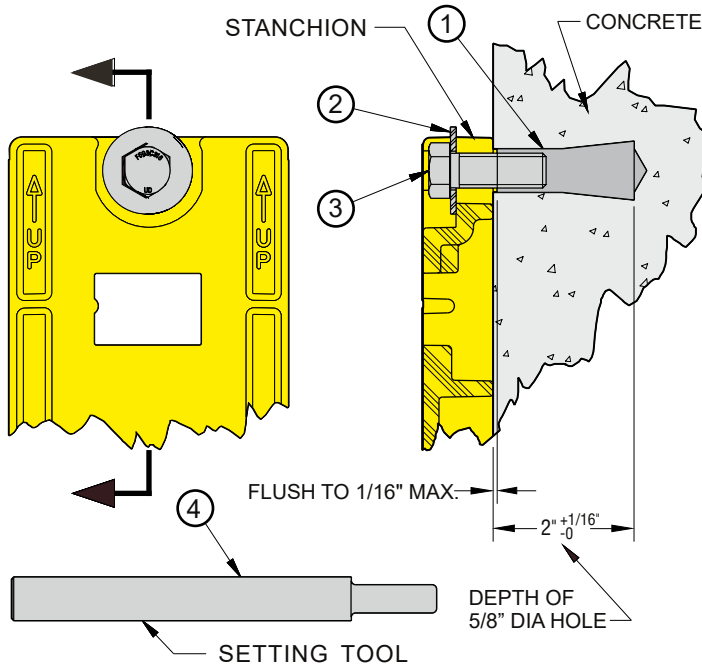

HARDWARE RECOMMENDED FOR SECURING THE HEAVY DUTY RACK STANCHION TO A FINISHED CONCRETE WALL		
ITEM NO.	CATALOG NUMBER	DESCRIPTION
①	FSRM-12	1/2" - 13 DROP-IN ANCHOR MATERIAL: 18-8 SS
②	FFW-316-18-040	FLAT WASHER 0.56 ID X 1.25 OD X 0.078 THICK MATERIAL: 316 SS
③	FHC-316-16-044	HEX HEAD CAP SCREW 1/2"-13 X 1 3/8" MATERIAL: 316 SS
④	FRT-112	SETTING TOOL (TO INSTALL FSRM-12 ANCHOR)

## ANCHOR LOAD CAPACITY:

1. Ultimate pull out capacity = 8,544 lbs. Ultimate shear capacity = 6,502 lbs.
2. Ultimate load capacity is based on 4,310 psi 3/4" crushed limestone aggregate concrete. Based on independent testing laboratory tests. Copies of reports are available upon request.
3. For load capacities in structural lightweight aggregate concrete contact Underground Devices, Inc.
4. Safe working loads for single installations under static loading should not exceed 25% of the ultimate load capacity.

## GENERAL ANCHOR NOTES:

1. Caution: UDI drop-in anchors are designed to operate only when installed with UDI brand setting tools.
2. The use of a 24 to 40 ounce hammer is recommended for expanding UDI drop-in anchors.
3. Anchors should be installed with carbide tipped hammer drill bits made in accordance to ANSI B212.15-1994 specifications.
4. UDI drop-in anchors are tested to ASTM E488 and are approved and listed by agencies as required by local building codes.
5. UDI drop-in anchors are not recommended for use in new concrete which has not had sufficient time to cure.
6. UDI drop-in anchors are not recommended for use in light weight masonry such as block or brick.

## HEX HEAD CAP SCREW NOTES:

1. UDI Type 316 stainless steel cap screws conform to ASTM 316F593G and ASME B18.2.1.
2. "316F593G" and the manufacturer's identification number is stamped on the head of each Type 313 stainless steel screw.
3. The manufacturing lot number is marked on each carton of fasteners and has full traceability.
4. Upon request UDI will supply written certification that a given lot of fasteners conforms to the applicable specification.

## GENERAL INSTALLATION GUIDELINES For the highest cable rack load capacity:

1. Be sure the surface of the concrete wall is smooth, flat and plumb.
2. Install one fastener in every elongated stanchion hole.
3. Install each drop-in anchor as shown in the drawing above and as described below:
  - A. Drill a 5/8" diameter hole 2" deep.
  - B. Blow out hole.
  - C. Drive anchor flush to 1/16" below surface of concrete.
  - D. Expand anchor with FRT-112 setting tool. Anchor is properly set when shoulder of setting tool is flush with the top of anchor.
4. Install the flat washer and tighten the cap screw just enough to attain a snug fit. Avoid high screw torque which induces compressive stress.
5. After assembling the arms to the stanchion, tap the arm down with a light mallet blow. The light mallet blow will fully seat and lock arm in place.
6. Install optional HDL lock by placing the lock on the arm with the locking barbs up. Push the lock into the rectangular hole in the stanchion. When the stop flanges on the lock hit the stanchion, the lock will click into place.

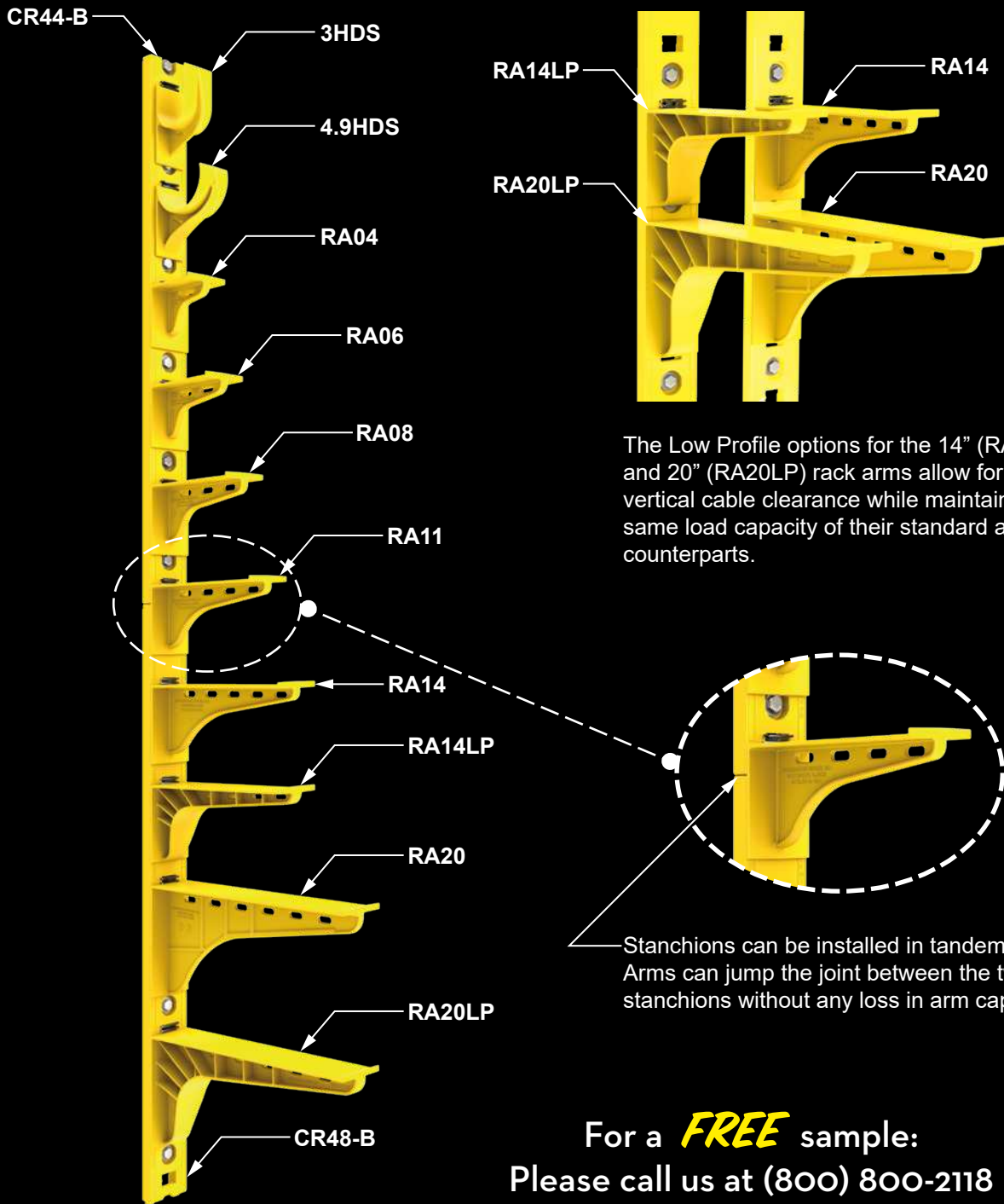

The Low Profile options for the 14" (RA14LP) and 20" (RA20LP) rack arms allow for greater vertical cable clearance while maintaining the same load capacity of their standard arm counterparts.

Stanchions can be installed in tandem. Arms can jump the joint between the two stanchions without any loss in arm capacity.

For a **FREE** sample:  
 Please call us at (800) 800-2118  
 -or-  
 Email us at [samples@udevices.com](mailto:samples@udevices.com)

LIMITED WARRANTY: UNDERGROUND DEVICES, INC. Warrants to the original purchaser that the goods manufactured by it are free from defects in material and workmanship for a period of one year from the date of purchase. Consequences of improper selection or installation of UNDERGROUND DEVICES product on any application over any period of time is the sole responsibility of the Purchaser or User. UNDERGROUND DEVICES liability is limited to replacement of, or credit for, defective products. UNDERGROUND DEVICES, INC. WILL IN NO EVENT BE LIABLE FOR INCIDENTAL OR CONSEQUENTIAL DAMAGES.

**UNDERGROUND DEVICES**  
 INCORPORATED



420 ACADEMY DRIVE  
 NORTHBROOK, IL 60062  
 Phone: 847-205-9000 • Fax: 847-205-9004  
 Website: [www.udevices.com](http://www.udevices.com)